



Enwa BIN-X[®]



- BIN-X (UF) Ultrafiltration, membrane technology
- Protection against Legionella and e-coli
- Particle filtration down to 0.03 microns
- Environmentally friendly and without the use of chemicals
- DWI approved
- Capacities from 75 l / h. to 50,000 l / h.

Enwa BIN-X®

ENWA BIN-X® is a patent-protected, cost-effective water treatment system, which uses filtration technology to purify drinking and potable water. ENWA BIN-X® provides maximum protection against the growth of bacteria such as legionella and e-coli.

Benefits

- Provides maximum protection against Legionella, e-coli and other bacteria and particles
- Automatic rinsing (Backwash) - controlled by PLC or electronic timer
- Allows for a gradual temperature reduction in domestic hot water systems resulting in reduced energy costs
- High security - long life
- Low operating costs - reduced service costs.
- Approved for installation on drinking water systems (DWI approved)
- Installed directly on main inlet and circulating hot water
- The system is driven by the mains water pressure (2-7 bar)
- Avoids downtime in the event of contamination from the water supply
- References from large and small installations



Installation

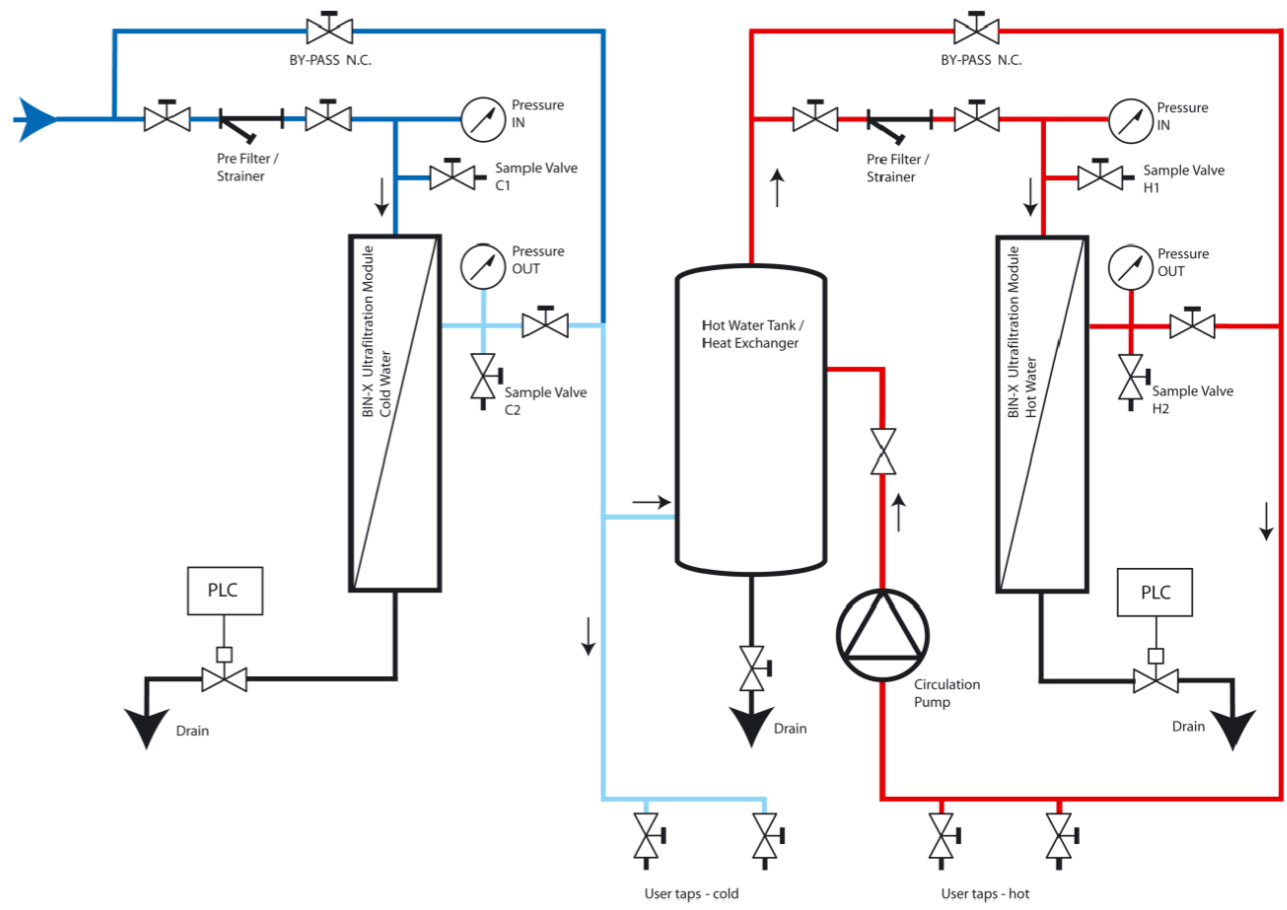

Schematic diagram: Installation overview for BIN-X Ultrafiltration of cold and hot domestic water

Applications

- Drinking water
- Hospitals and nursing homes
- Exploration rigs and fixed installations offshore
- Sea going vessels
- Cooling towers
- Housing
- Higher education
- Sports facilities
- Industrial water (Process water)
- Laboratories
- Drinking water coolers and ice machines



Technical information

Cold water *	UF23	UF24	UF26	UF45	UF410 B1-B4	UF815 B1-B4
Maximum capacity (l / h)	35	100	150	400	3600	35000
Continuous capacity (l / h)				220	1800	17200
Continuous capacity (m / d)				5	43	413
Construction dimensions (l x w x h)	330x63x63	528x63x63	728x63x63	820x100x100	1398x500x1700	1600x750x1940
Weight (kg)	0.3	0.7	1	3.5	40-100	80-190
Power supply V / A				230 VAC 50-60 Hz	230 VAC 50-69 Hz	230 VAC 50-60 Hz

*For hot water, please consult with Enwa

Water is one of the world's most important resources and will always be crucial for people's lives, welfare and finances

Enwa offers water treatment solutions for industry, construction & real estate.

Safe drinking water, clean process water, corrosion protection and energy efficiency in heating and cooling systems are some of the areas where our expertise, products and solutions add value to the customer.

We are also a service contractor for heating and cooling systems and operate extensive service on all our products. We perform condition surveys and optimisation of heating and cooling systems.

Radiumospitalet, Oslo



Hotel Montebello, Oslo



University Hospital, Aalborg Denmark



Aabenraa Hospital, Denmark

ADVANCED WATER TECHNOLOGY



Tel: +44 1530 830 3540
email: uksales@enwa.com
www.enwa.com